

ADAYO

User Manual

SP2500 Potable Power Station

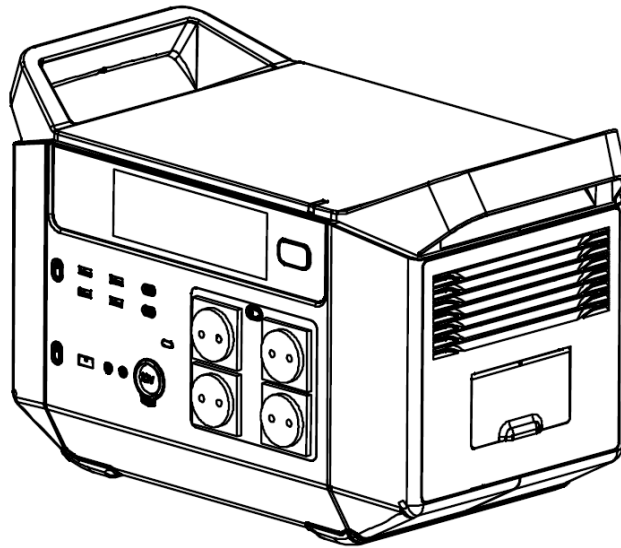

Please read the user manual carefully before using the product and keep it for future reference .

Disclaimer

Dear users,

Thank you for choosing our products and services. Before using the product, please read carefully and fully understand this document to ensure that you can use the product correctly. By using this product, you are deemed to have understood, recognized and accepted all the terms and contents of this document, and the user undertakes to be responsible for his own actions and all consequences arising therefrom.

Incorrect operation of the product or product abnormality caused by force majeure such as fire, typhoon, flood and earthquake may cause unnecessary harm to yourself or others or cause damage to this product and loss of property. All accidents and losses caused by this may have nothing to do with our company. Correspondingly, the service warranty terms promised to you will automatically become invalid.

Do not use the product in situations or with equipment that requires extremely high reliability or safety or in high-risk activities, such as the following:

- Medical equipment that directly affects human life.
- Equipment that may result in personal injury (such as equipment directly related to the operation and control of aircraft, ships, railroads, elevators, etc., or equipment that may be subject to constant vibration, such as automotive and marine equipment).

The product is not designed or intended for use in hazardous environments requiring fail-safe performance, or for use in any circumstance in which the failure of the product could lead directly to death, personal injury, severe physical or property damage, or that would

affect the operation or safety of any medical or life support device (collectively, "High-Risk Activities"). Our company expressly disclaims any express or implied warranty of fitness for High-Risk Activities. Our company does not authorize use of any product in any High-Risk Activities. Any such use is improper and is a misuse of the product.

In compliance with laws and regulations, our company has the final right to interpret product-related documents. If there is any update, revision or termination, no further notice will be given. Our company strives to ensure the accuracy of information such as product functions and features described in the user manual, but does not assume the responsibility for any errors, omissions or subtle differences between the user manual and the product.

If you still have questions, please visit our official website to get the latest product information.

1. Safety Instructions

■ Warning

1) Please read all the instructions carefully before using the product. Incorrect operation of the product may lead to accidents or injuries.

2) Avoid the product from contact with any liquid or absorbing moisture. Do not expose the product to rain, snow or high humidity. Do not use wet cloth to wipe the product. If the product gets moisturized or damp, please dry it thoroughly before use.

3) Do not use this product near a heat source, such as fire source or heating furnace. So as to avoid overheating damage to the product and the dangers arising therefrom.

4) Use the product under the specified conditions. Excessive temperature may cause product failure even permanent damage. If the temperature is too low, the performance of the product will be seriously reduced or stop working.

5) Do not use it in strong static electricity or strong magnetic field environment. This may cause the product to work abnormally or the protection function to fail, which may lead to accidents.

6) Be sure to use the product in a dry, well-ventilated place with little dust. Don't place the vent against the wind when using, and don't block the vent or forcibly lock the fan; Please do not place items within 5CM of the vent.

7) Working at extremely low air pressure may cause damage to the product.

8) Do not stack more than 30kg weight on the product; Don't put it with metal items such as necklaces, coin hairpins, etc.

9) Please store the product out of the reach of children and pets. Close supervision is necessary when the product is used near children.

10) Do not put fingers or hands into the product. Do not insert foreign objects, especially electric conductor, into any port (AC, DC or vent) of the product to avoid the risk of electric shock or product damage.

11) Do not use the product in excess of its output rating. Overload output exceeding the rated value may lead to product damage and other accidents. Please pay attention to the instantaneous power of the equipment when the product supplies power to the equipment with air compressor. The instantaneous power of such equipment far exceeds its rated value.

12) Do not clean the product with harmful chemicals or detergents.

13) Do not operate the product with a damaged electric plug or cord, or a damaged output

cable. To reduce risk of damage to the plug and cord, pull the plug rather than the cord when disconnecting the product.

14) Ensure that the product is not hit, dropped or violently vibrated. When transporting the product, please firmly fix the product to avoid damage. If the product suffers from severe external impact, please immediately turn off the power supply and stop using it.

15) This product must be grounded to reduce the risk of electric shock in the event of malfunction or breakdown. This product is equipped with a cord having an equipment grounding conductor and a grounding plug. The plug must be plugged into an outlet that is properly installed and grounded in accordance with all local codes and ordinances. Do not modify the plug provided with the product without a qualified electrician.

16) Do not disassemble in any way or puncture the product with sharp objects. Take it to a qualified service person when service or repair is required. Incorrect reassembly may result in a risk of fire or electric shock. To reduce the risk of electric shock, unplug the product from the outlet before attempting any instructed servicing. Repair it using only identical replacement parts.

17) Do not use the product that is damaged or modified. Damaged or modified batteries may exhibit unpredictable behavior resulting in fire, explosion or risk of injury.

18) Do not use unofficial parts or accessories. If you need to replace it, please go to the sales channel designated by our company to inquire about the relevant purchase information.

19) If the product is at risk of serious damage (such as water ingress) or has been seriously damaged, please immediately cut off the power supply connection to the product and turn off it. Place the product in an open, waterproof and safe place, away from people and flammable materials. Please take measures to prevent electric shock before touching the product. The product shall not be reused and shall be disposed of according to local laws and regulations.

20) If the product catches fire accidentally, it is recommended to use fire extinguishing equipment in the following order: sand, fire blanket, dry powder and carbon dioxide fire extinguisher.

21) Do not use the product in situations or with equipment that requires extremely high reliability or safety or in high-risk activities.

22) The product has sleeping function. Some devices in standby state, such as refrigerators, may be recognized as off by the product, which will cause the product to enter a sleeping state for a long time and cannot continuously supply power to the device. Do not use the product when continuous power supply is required for the equipment.

23) There are lithium batteries in the product, so you can't carry them on board. According to international shipping conventions, carrying lithium batteries on board can't exceed 100Wh. This product exceeds the prescribed boarding limit.

■ Disposal



1) The product life is exhausted or the battery can't be started due to over-discharge, so it is no longer of maintenance value. If conditions permit, please confirm that after the product is completely discharged, it should be placed in the designated recycling box for disposal, or handed over to a professional recycling agency for batteries. For more details, please follow the local laws and regulations on battery recycling and disposal.

2) The product is scrapped due to accidental damage or its own fault, and the battery can't be discharged completely. Please don't directly discard the battery in the battery recycling box, leaving a potential safety hazard. You should contact a professional battery recycling agency.

2. Production Introduction

This portable power station product adopts the LiFePO4 battery with high safety level, and has a long cycle life. Provide abundant output power supply ports and input charging ports. The product adopts bidirectional inversion technology, and supports super fast charging, which can greatly shorten the charging time. And it has a variety of smart functions, including EPS, super load, smart car-charging and auto-charging. And it also supports a variety of external charging methods, including AC charging, solar charging, car-charging, and DC adapter charging.

■ Appearance and keys

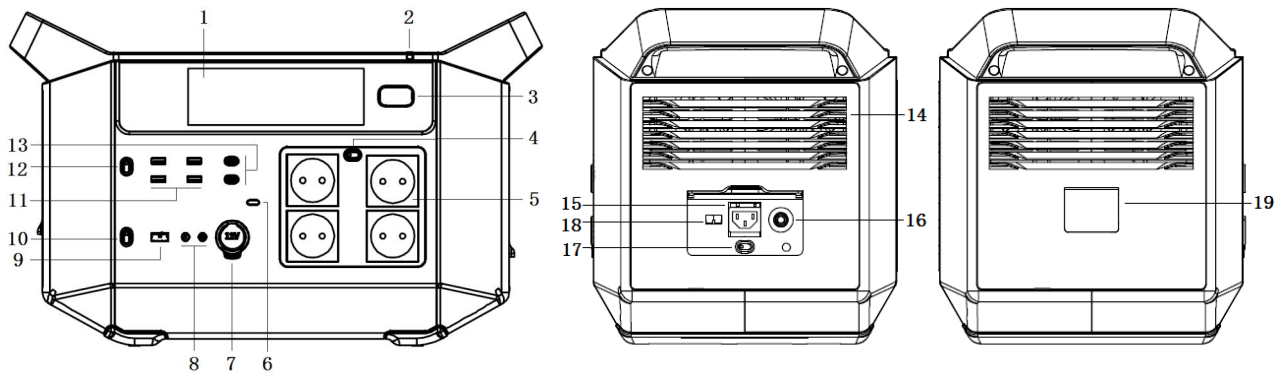

1.Screen	2.Power indicator light	3.Power switch	4.AC output switch
5.AC output port	6.key tone switch	7.Cigar lighter output port	8.DC5521 output port
9.Anderson output port	10.DC output switch	11.USB-A output port	12.USB output switch
13.Type-C output port	14.Vent	15.AC input port	16.AC input reset button
17.Fast charging switch	18.DC input port(Anderson)	19.Extra battery port(Not enabled)	

■ Interactive interface

1) Screen display



Indicator	Description	Indicator	Description
	Percentage of battery capacity		Charge/discharge remaining time*1
	AC output on		Charging. Rolling display ().
	AC input/output frequency		Fast charging on
	DC output on		USB output on
	Charging power		Discharging power
	EPS mode on		Fan working
	Flashes as AC output over rated power, is always on as overload.		Fan failure
	Battery failure		DC output has failure and is off.
	USB output has failure and is off.		AC output has failure and is off.
	AC input is abnormal.		DC input is abnormal.
	High-temp alarm for power devices when all flashing. Output is off.		Low-temp alarm for power devices when all flashing. Output is off.
	High-temp alarm for battery when all flashing. Output is off.		Low-temp alarm for battery when all flashing. Output is off.

*1: When the "HOURS" indicator is on, the unit of the remaining time value is hour. When the "MIN" indicator is on, the unit is minute. When the input power is greater than the output, it shows the remaining time of battery full charge, and vice versa, shows the remaining time of battery complete discharge.

2) Power indicator light

When the battery power is above 20%, it is green. When below 20%, it is red.

■ Specifications

Item	Specification	Remark
Basic specifications		
Rated AC output	2500W	230V 50Hz, pure sine wave
Battery energy	2496Wh	48V LiFePO4 battery
Battery cycle Life	4000 cycles	25°C, 70% capacity left
Dimension	51.5*29.2*32.2cm	
Weight	about 25.5kg	
Total input power	1400W max	AC 1400W max, DC 800W max
Charging temperature	0~40°C	
Discharge temperature	-20~45°C	
Storage temperature	Short-term(<3 months): -20~45°C Long-term(3~12 months): 0~25°C	The product not used needs to be charged once every three months.
Smart functions		
EPS	Start-up time ≤30ms	Start when AC input is interrupted.
Super load	Rated power of load <3900W	Supports loads exceeding the rated power of the product. *1
Smart car-charging	Smart recognition for car-charging	The function is not available when the car engine is not working.
Auto-charging	Maintain 90% capacity	Auto-charging when the product is long-term connected to the grid.
Output ports specifications		
AC output (×4)	Rated 2500W peak power <4500W	Total power of 4 ports < 2500W. Max power of one single port is 2500W.
USB-A output (×4)	5V_3A,9V_2A,12V_1.5A; max 18W	Switched by USB output switch.
Type-C output (×2)	5V_3A,9V/12V/15V/20V_5A; max 100W	
Cigar lighter output (×1)	13V_10A max; 130W	Switched by DC output switch. Total current of the four ports is 15A max.
DC5521 output (×2)	13V_3A max; 39W	
Anderson output (×1)	13V_15A max; 195W	
Input ports specifications		
AC input	1400W max	Charging time is about 2.4H.
DC input (car-charging)	13.2V, max 8A	Charging time is about 26H.
DC input (solar charging)	18V~40V, max 22A	Fastest charging time is 3.5H.

*1: Super load function is not suitable for appliances with strict voltage requirements. Appliances with voltage protection are not supported. Super load function is more suitable for heating devices.

3. Use of products

■ On-off and output

1) On-off

The power switch button is the control button for turning on and off the product.

- ① Press the power switch briefly to start the product;
- ② Press and hold the power switch for 2 seconds in the start-up state, and turn it off.
- ③ Press the power switch briefly in the start-up state , and the screen display will switch back and forth between on and off.

When the product is turned on, the screen lights up, and the power indicator light at the top of the product lights up. When there is no operation for 5 minutes, the screen will automatically go out. If it is not operated for more than 12H, the product will be shut down.

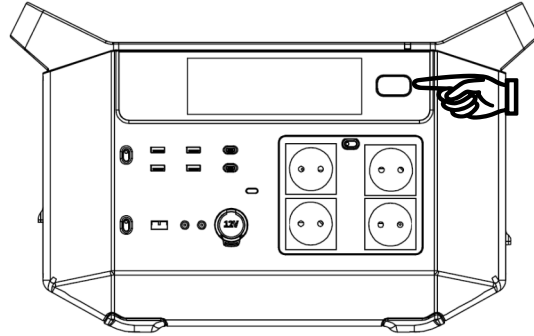

2) DC output

① Press the DC output switch button briefly in the start-up state, and the DC output will be turned on. The cigar lighter port, DC5211 ports and Anderson output port can output power supply, while the DC output switch indicator lights up. A suitable device can be plugged into the port to power the device.

② Press the DC output switch button again, the DC output will be turned off, and the DC output switch indicator will be turned off.

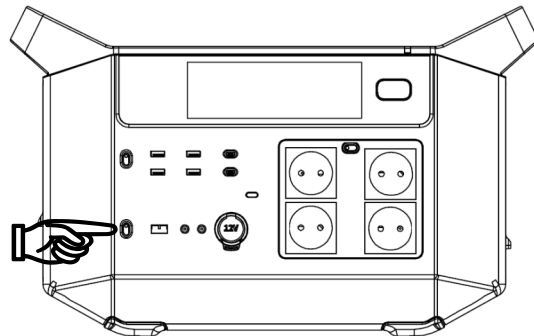

3) USB output

① Press the USB output switch button briefly in the start-up state, and the USB output will be turned on. The USB-A and Type-C output ports can output power, while the USB output switch indicator lights up. A suitable device can be plugged into the ports to power

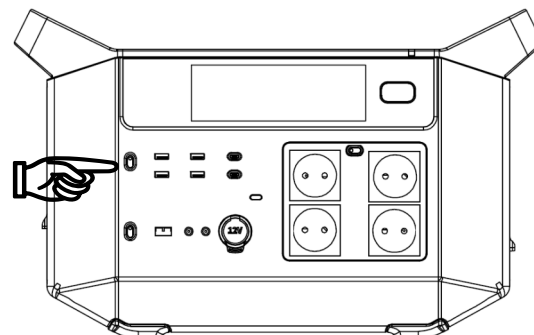

the device.

② Press the USB output switch button again, the USB output will be turned off, and the USB output switch indicator will be turned off.

4) AC output

① Press the AC output switch button briefly in the start-up state, and the AC output will be turned on. The AC output ports can output power supply, while the AC output switch indicator lights up. A suitable device can be plugged into the port to power the device.

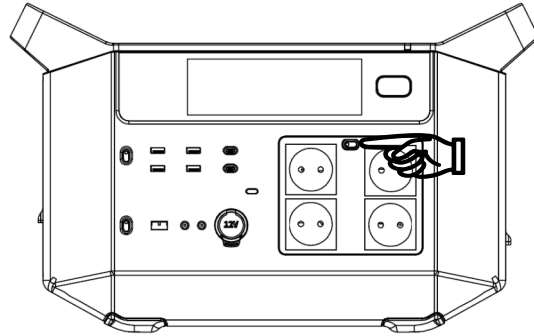

② Press the AC output switch button again, the AC output will be turned off, and the AC output switch indicator will be turned off.

When the AC input port is connected to the grid, the EPS(Emergency Power Supply) mode is turned on. The AC output ports will take power directly from the AC input port. In EPS mode, once the power cannot be supplied due to abnormal AC input, the product switches to battery power supply immediately, and the switching time is within 30ms. In EPS mode the AC output power cannot exceed 1100W, otherwise the AC input will be cut off for protection.

AC output is supported during DC charging.

⚠ Note:

- ① The instantaneous power of the load connected to the AC output port cannot exceed 50% of the rated power of the product, otherwise it will cause power failure protection or even damage.
- ② Output ports on the front panel of the product is not for power input. Do not input power to these ports. Otherwise it will cause product damage and other accidents.

■ Input(Charging)

1) AC input

After connecting the AC input port to the grid through the AC power cord:

① The product charges the battery according to the set charging power. If the product is turned off, the product will be woken up first and then charged.

②The product is set with two charging ways: standard charging which is default and fast charging. Standard charging takes about 3.3 hours to fully charge and and fast charging takes about 2.4 hours. You can switch between standard charging and fast charging through the fast charging switch. Fast charging does not work in EPS mode.

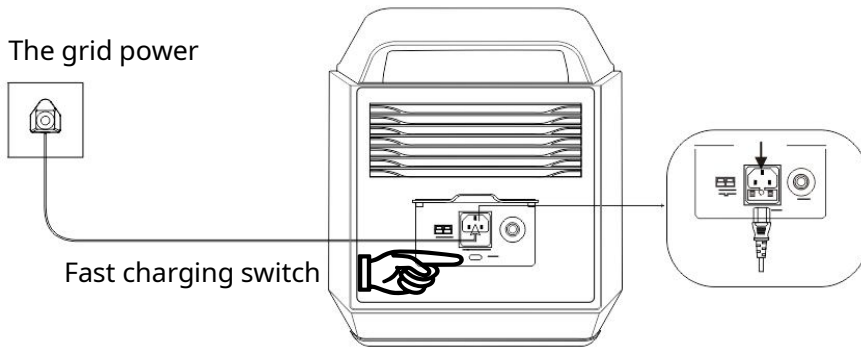

2) Input from car (car-charging)

After connecting the DC input port to the cigar lighter output port of the car:

- ①The product automatically recognizes car-charging input and charges according to the set limit current. If the product is turned off, the product will be woken up first and then charged.
- ②The product can be charged and discharged simultaneously.
- ③The product has smart car-charging function, which can intelligently identify whether the engine of the fuel vehicle works or not . In order to protect the 12V battery of the car, car-charging will be turned off until the engine works.

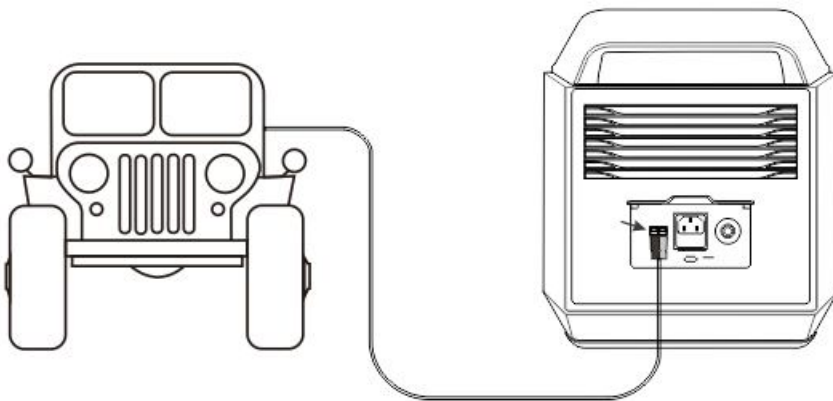

3) Solar charging

After connecting the DC input port to solar panel:

- ①The product automatically recognizes solar charging input and automatically tracks the maximum power point (MPPT). If the product is turned off, the product will be woken up first and then charged.

②The product can be charged and discharged simultaneously.

③Switch between standard charging and fast charging through the fast charging switch. DC input in standard charging mode is limit to 400W.

⚠ Note:

①Solar panels are light and temperature sensitive devices, and the fluctuation of charging power is a normal phenomenon during solar charging.

②Please use the solar panel with proper configuration, otherwise it may cause damage. If several solar panels are connected, please use them in parallel. If you want to use it in series, please first confirm whether the voltage in series meets the voltage requirements of the product DC input port.

③Our company will not be responsible for product damage caused by improper use of solar panels and improper operation. Do not attempt to plug the Anderson terminal of DC input into the Anderson output port on the front panel of the product.

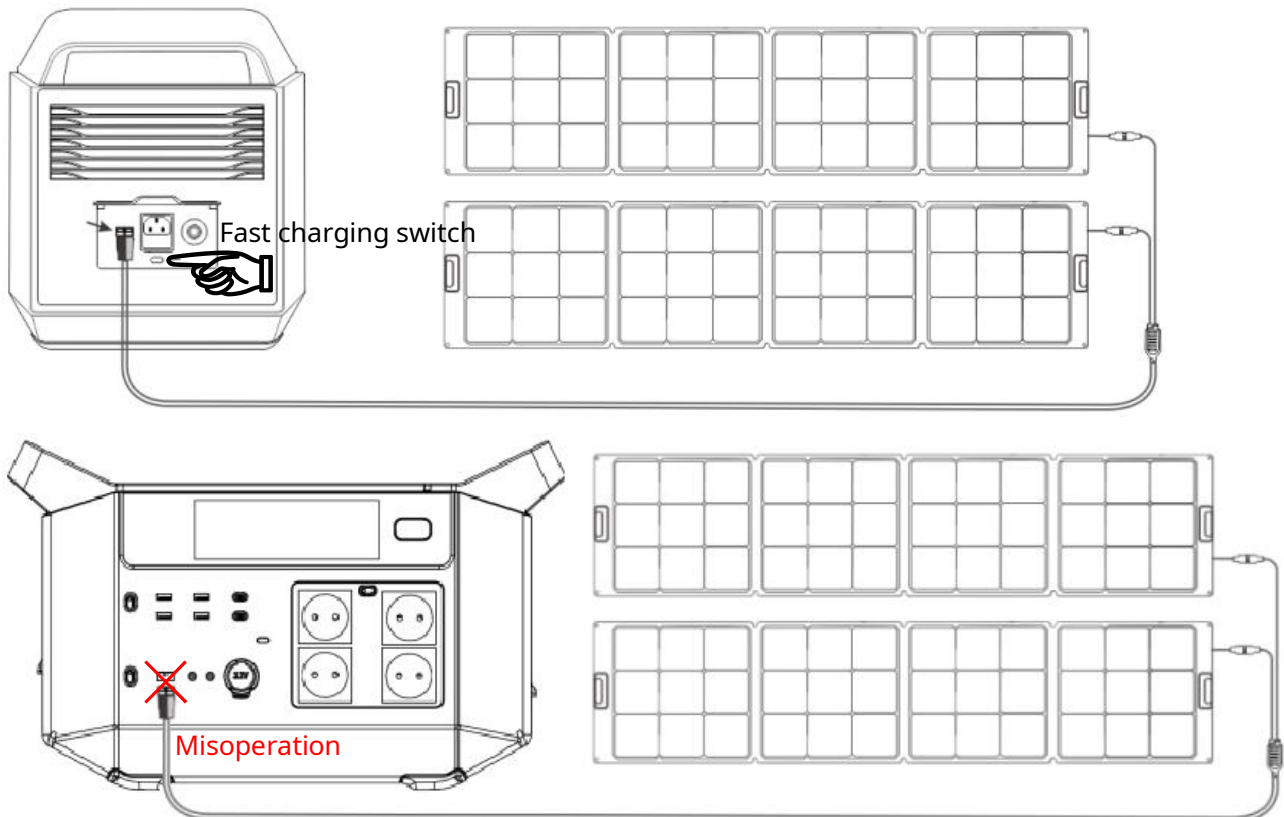

■ Smart functions

1) EPS mode

In EPS mode AC output takes power from AC input directly and pass by the battery.

①After the AC input is connected to the grid, the AC output is switched from the battery to the grid power lines to get power when the AC output is turned on.

②When the AC input is abnormally unable to supply power, the product will switch to battery power supply immediately to maintain power supply of AC output, and the switching time is within 30ms.

⚠ Note:

①EPS mode power supply has switching time and cannot replace professional UPS products. When using, please confirm whether it meets the power demand of devices.

②In EPS mode, the output power of the product cannot exceed 1100W, otherwise the AC input will be cut off for protection.

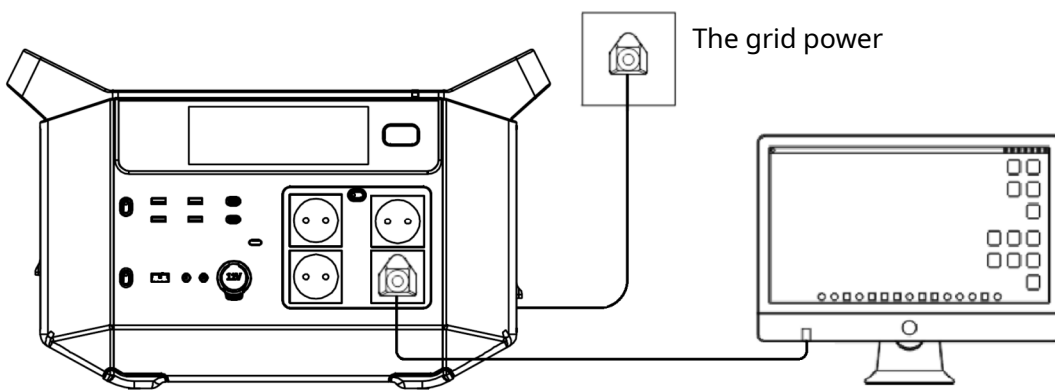

2) Super load

The product supports AC output loads with rated power up to 1.56 times that of the product. When connecting a load with rated power greater than the product, the product keeps the output power at the rated power by reducing the output voltage.











⚠ Note:

Super load function is not suitable for appliances with strict voltage requirements. Appliances with voltage protection are not supported. Super load function is more suitable for heating devices.

3) Auto-charging

In order to make the product have enough power after long-term non-use, the AC input port can always be connected to the grid, and the product will automatically charge. When the product detects that the power is less than 90%, it will automatically get power from the grid.

4. Troubleshooting

Indicator	Failure description	Recovery action
OVERLOAD	Flashes as AC output over rated power, is always on as overload.	Manually press the output switch to recover after the fault is removed.
	Fan failure. Output is off.	Manually press the output switch to recover after the fault is removed.
	Battery failure. Output is off.	Manually press the output switch to recover after the fault is removed.
	DC output has failure and is off.	Manually press the output switch to recover after the fault is removed.
	USB output has failure and is off.	Manually press the output switch to recover after the fault is removed.
	AC output has failure and is off.	Manually press the output switch to recover after the fault is removed.
	AC input is abnormal.	In case of grid power voltage problem, the product will return to normal after the voltage is normal. For over-current protection, press AC input reset button manually to restore it.
	DC input is abnormal.	The product will return to normal after the DC input is normal.
	High-temp alarm for power devices when all flashing. Output is off.	Manually press the output switch to recover after the fault is removed.
	Low-temp alarm for power devices when all flashing. Output is off.	Manually press the output switch to recover after the fault is removed.
	High-temp alarm for battery when all flashing. Output is off.	Manually press the output switch to recover after the fault is removed.
	Low-temp alarm for battery when all flashing. Output is off.	Manually press the output switch to recover after the fault is removed.

Note:

- ① If the above recovery action cannot solve the problem, please shut down the product and restart. If restarting can not solve the problem, please contact the sales channel designated by our company.
- ② If the product can't be started, please try to charge the product first. If charging can not solve the problem, please contact the sales channel designated by our company.

5. Maintenance

1) The product should be used and stored in a suitable temperature, low humidity and non-corrosive environment, away from heat sources, water sources and metal conductive articles.

2) In order to prolong the service life of the battery, it is recommended to use this product in the temperature environment of 20°C to 30°C.

3) Do not short-circuit, over-charge or over-discharge the product.

4) If the power of the product is lower than 1% after use, please charge it to more than 60% capacity before storing it. If it is placed for a long time under the condition of serious shortage of electricity, the battery cell will be irreversibly damaged and the service life of the product will be shortened.

5) Before short-term storage (< 3 months), the power of the product should be charged to more than 30% capacity, and before long-term storage (3~12 months), it should be charged to more than 60%.

6) If the product has not been used for a long time or the power is seriously insufficient, it needs to be recharged before it can be used again.

7) Because the transportation safety product cannot store too much electricity before delivery. Due to the consumption of the product itself during the storage period, the product delivered to the client can't be completely guaranteed to enter the working state immediately. The product may need to be recharged before continuing to use.

8) During the transportation and handling of the product, severe vibration, impact, exposure to the sun and rain should be prevented.

6. FAQ

Q1: What should I pay attention to before using the product?

Before using the product, please read carefully and fully understand user manual to ensure that you can use the product correctly.

Q2: Why does the product not work?

Please refer to the troubleshooting section of the user manual and solve the problems according to the instructions.

Q3: Can I use a solar panel that is not recommended by the manufacturer to charge the product?

Yes, you can. But before use, please confirm whether the parameters of the solar panel meet the requirements of the DC input port of the product.

Q4: Can I use the product in rainy days?

No. The product is not waterproof, please don't use it in rainy, snowy and thunderous weather. And do not use it in extremely cold and high temperature environment.

Q5: Can the product be stored for a long time?

There are lithium batteries in the product. The batteries have self-consumption. If you don't use the product for a long time, the batteries will be exhausted and be damaged further. Please store and maintain the product according to the instructions in the user manual.

Q6: Which devices can the product power?

The product can charge digital devices, such as mobile phones, through DC and USB output ports; Appliances, such as ovens, can be charged through AC output ports. Please confirm whether the rated power of the appliances meets the power requirements of the product output ports before use.

Q7: How to understand the remaining time value displayed on the screen?

When the "HOURS" indicator is on, the unit of the remaining time value is hour. When the "MIN" indicator is on, the unit is minute. When the input power is greater than the output, it shows the remaining time of battery full charge, and vice versa, shows the remaining time of battery complete

discharge.

Q8: How to charge the product?

You can use the grid power to charge the product through AC input port. Also you can use solar panels to charge it through DC input ports. And there are other ways. See the user manual for details. The input(charging) ports are on the right side of the product, please be careful not to use the output ports on the front panel of the product by mistake to charge the product.

Q9: When do I need to charge the product?

When the power indicator light is red, the battery power is below 20%. Please charge the product.

Q10: Why are the indicators on the product screen flashing?

There may be something wrong with the product. Please confirm the problem according to the user manual.

7. Packaging content

1) Product

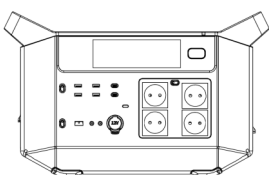

2) AC Charging line

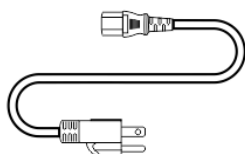

3) Manual

